

Series 1780 Dynamometer V2 Datasheet

Typical use

- Outrunner brushless motor characterization
 - 25 kgf / 0-100 A
 - 40 kgf / 0-150 A
 - 75 kgf / 0-500 A
- Propeller characterization up to 70"
- Servo testing and control
- Battery endurance testing
- Factory testing



Features list

- Direct measurements
 - Torque
 - Thrust
 - Voltage
 - Current
 - Optical RPM
 - Temperature (three ports for each load measurement unit)
 - Air speed (probe requested)
- Derived measurements
 - Motor efficiency (%)
 - Propeller efficiency (g/W)
 - System global performance
 - (for two-motor setups)
- USB interface
- ESC manual control
- Load cell overload alarm and cutoff
- Automatic tests and recording
- Galvanic isolation
- Output data to CSV files
- Real-time sensor plots
- Powerful scripting
- Support for temperature probes
- Support for air-speed probes
- External cutoff switch and buzzer
- Factory calibrated
- Support multiple setups: single motor, coaxial back-to-back and coaxial face-to-face

Technical specifications

Table 1: Design specifications of the Series 1780 Single-motor (25 kgf - 100 A) version.

Specification	Min.	Max.	Tolerance	Unit
Thrust	-25	25	0.5%	kgf
Torque	-12	12	0.5%	Nm
Voltage	0	60	0.5%	V
Current	0	100	1%	A
Angular speed*	0	190k	-	RPM

*Optical RPM.

Table 2: Design specifications of the Series 1780 Single-motor (40 kgf - 150 A) version.

Specification	Min.	Max.	Tolerance	Unit
Thrust	-40	40	0.5%	kgf
Torque	-18	18	0.5%	Nm
Voltage	0	60	0.5%	V
Current	0	150	1%	A
Angular speed*	0	190k	-	RPM

*Optical RPM.

Sampling rate depends on your computer (50Hz+).

Due to the vibration isolators, expect hysteresis of a maximum of 100 g in thrust after full range testing. Tare the load sensor (from the software) before running a test.

Table 3: Design specifications of the Series 1780 **Coaxial** (25 kgf - 100 A) versions.

Specification	Min.	Max.	Tolerance**	
			*	Unit
Thrust side A*	-25	25	0.5%	kgf
Thrust side B	-25	25	0.5%	kgf
Torque side A	-12	12	0.5%	Nm
Torque side B	-12	12	0.5%	Nm
Voltage side A	0	60	0.5%	V
Voltage side B	0	60	0.5%	V
Current side A	0	100	1%	A
Current side B	0	100	1%	A
Angular speed**	0	190k	1	RPM

* Each side represents one motor and one propeller. The system can acquire data for both A and B sides in order to calculate a global performance.

** Optical RPM included.

*** Guaranteed tolerance is for the full scale range, meaning thrust accuracy is 0.005 * 25kg = 125g. In practice 30g error under static measurements is expected. Vibrations may increase the error.

**** This table applies to both Basic coaxial and Ultimate coaxial

Table 4: Design specifications of the Series 1780 **Coaxial** (40 kgf - 150 A) versions.

Specification	Min.	Max.	Tolerance**	
			*	Unit
Thrust side A*	-40	40	0.5%	kgf
Thrust side B	-40	40	0.5%	kgf
Torque side A	-18	18	0.5%	Nm
Torque side B	-18	18	0.5%	Nm
Voltage side A	0	60	0.5%	V
Voltage side B	0	60	0.5%	V
Current side A	0	150	1%	A
Current side B	0	150	1%	A
Angular speed**	0	190k	1	RPM

* Each side represents one motor and one propeller. The system can acquire data for both A and B sides in order to calculate a global performance.

** Optical RPM included.

*** Guaranteed tolerance is for the full scale range, meaning thrust accuracy is $0.005 * 40\text{kg} = 0.2\text{kg}$. In practice 30g error under static measurements is expected. Vibrations may increase the error.

**** This table applies to both Basic coaxial and Ultimate coaxial

Table 5: Design specifications of the Series 1780 Single-motor (75 kgf - 500 A) version.

Specification	Min.	Max.	Tolerance	Unit
Thrust	-75	75	1%	kgf
Torque	-48	48	1%	Nm
Voltage	0	100	0.5%	V
Current	0	500	1%	A
Angular speed*	0	100k	-	RPM

*Optical RPM.

The load, power and optical RPM measurement units from side A and side B share the same design parameters. Thus, for the Series 1780 coaxial, users can expect a maximum total thrust of 50kgf (110lbf) for a Series 1780 Dynamometer 25 kgf - 100 A version and 80kgf (175lbf) for a Series 1780 Dynamometer 40 kgf - 150 A version (for the overall system). Note that the coaxial version is currently not available for the Series 1780 Single-motor 75 kgf - 100 A version.

Software features list

- Real time graphs
- Manual motor control
- Manual servo control
- Safety cutoffs based on any measured data
- Data recording to CSV file
- Automated tests
 - Ramps
 - Steps
 - Measure number of poles
 - And more with our scripting engine...
- User scripts with documentation

Hardware

The RCbenchmark dynamometer 1780 is designed to greatly reduce the time required for characterizing and testing high power brushless motors and large propellers, while obtaining precise and accurate results. Figure 1 and Figure 2 show an overview of the important components of the tool.

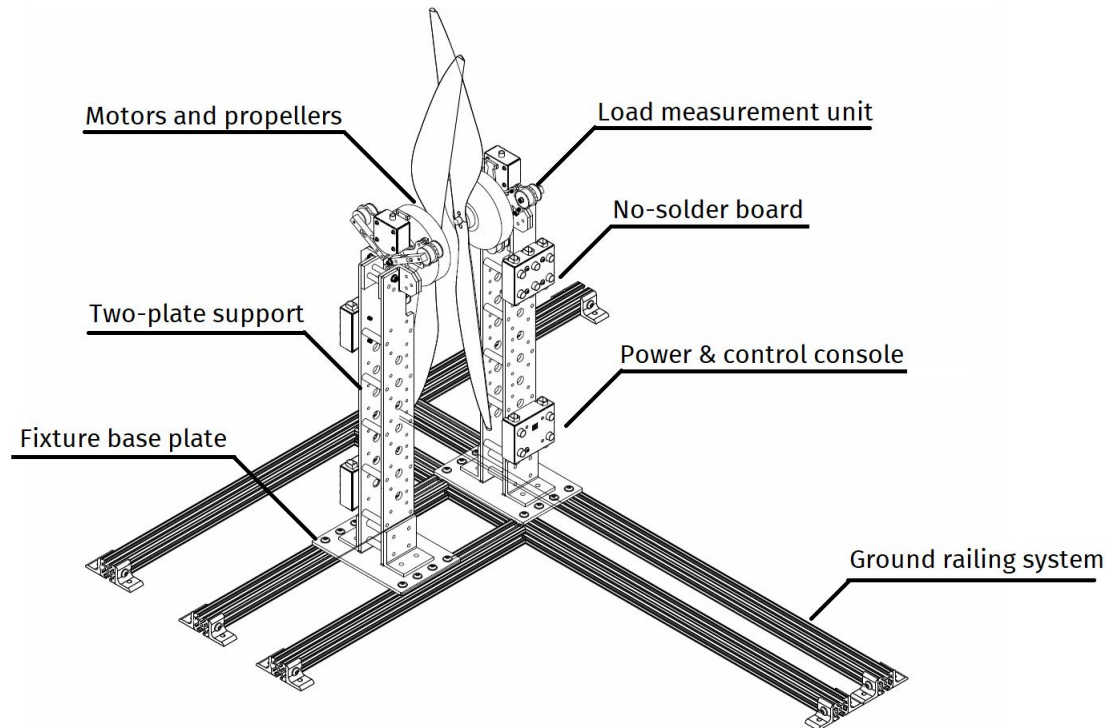

Fig. 1: Hardware overview for 25kgf and 40kgf versions

For a given voltage, brushless motor speed is a function of two variables: the mechanical load (in Nm), and the input (which can be measured in duty cycle or percentage of the maximum command sent to the ESC). The motors are characterized by changing the input from the software and by changing the load with multiple propellers. The load changes as the propellers have different size and pitch.

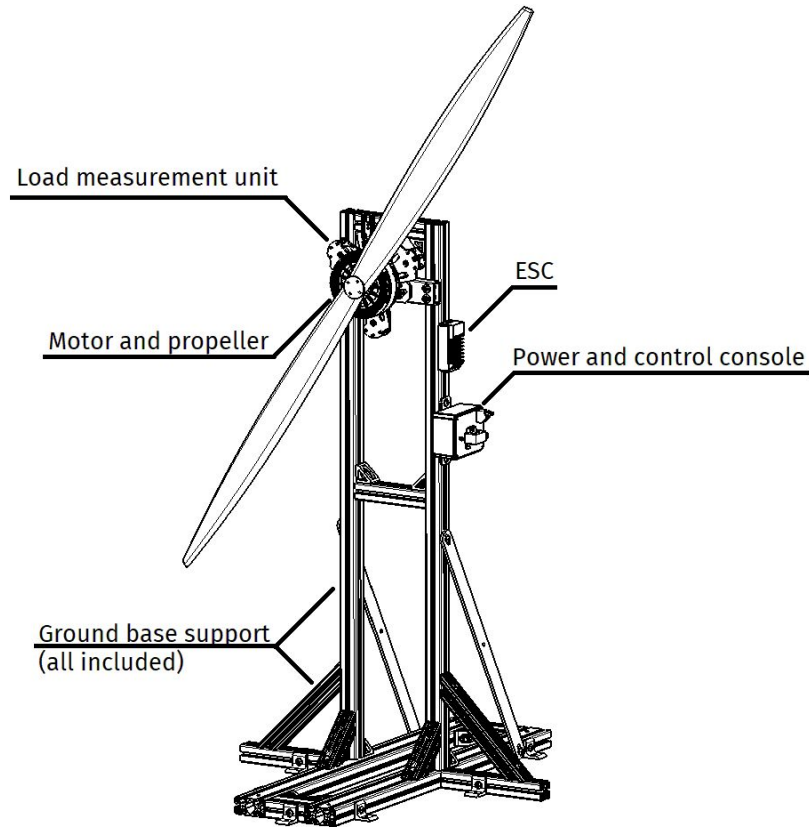

Fig. 2: Hardware overview for 75kgf version

Mountings and Assemblies

The load measurement unit is pre-assembled and calibrated before its shipment. Users will need to fix the unit onto the two-plate support or the ground based support, and finish assembling it with the motor mount, the optical RPM probe and other electrical components. Detailed instructions are provided in the user manual.

It is highly recommended to use the given supports to hold the load measurement units. Six holes for M5 bolts on the load measurement unit are reserved for support.

All necessary fasteners and hand-tools for mounting and assembling were included in all lines of the Series 1780 product.

Configurations

The Series 1780 is designed to be modular. Those modules can be replaced or reconfigured to adapt to different testing needs. Currently, you can order the Series 1780 dynamometer in three different configurations: Single-motor, Basic coaxial and Ultimate Coaxial.

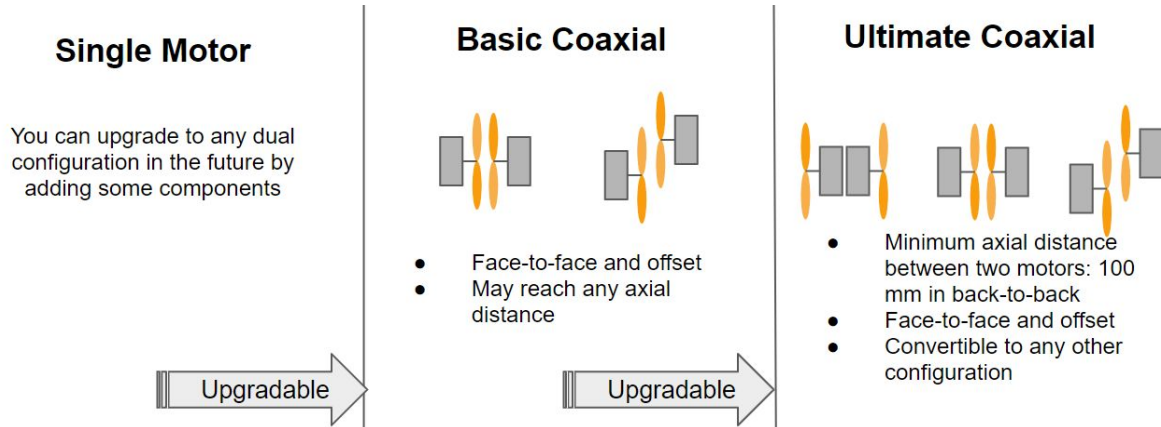

Fig. 3: Available configurations

All three configurations share mostly the same hardwares, except that the Ultimate coaxial contains special mounting to connect two measurement units together. These configurations can be used to test different setups: one motor, two motors face-to-face, two motors offset and two motors back-to-back. When testing two motors, coaxial configurations with an upgraded data acquisition board will allow to control and to process data for two motors simultaneously.

The power and control console, the optical RPM probe, the motor mounts and the fixtures are universal to all the configurations. It is possible to upgrade a configuration by purchasing extra components. Please contact the RCbenchmark technical support team for more details.

All RCbenchmark Series 1780 dynamometers are calibrated before product's shipment. Upon reception of the product, you may mount the unit onto the test bench and start testing right away.

Please take note that coaxial configurations are currently only offered on the 25 kgf - 100A and the 40 kgf - 150 A.

Compatible Motors

The motor mounts of the Dynamometer Series 1780 are compatible with most brushless motors for UAVs on the market. It contains three major features:

Attachment points to install the motor mount to the load measurement unit with the standoffs and M5 nuts.

Two tapped holes to install the optical probe to the motor mount with the supplied spacers and M4 screws.

For the 25 kgf and 40 kgf versions, the motor can be mounted directly on the motor mount with M3, M4, M5, M6 screws. The screws go through slots. There are slots at 0, 90, 120, 180, 240, 270 degrees in order to adapt to multiple motor geometries. For inrunner motor testing, there is also a center hole of $\phi 15$ that allows a rotating shaft through the plate.

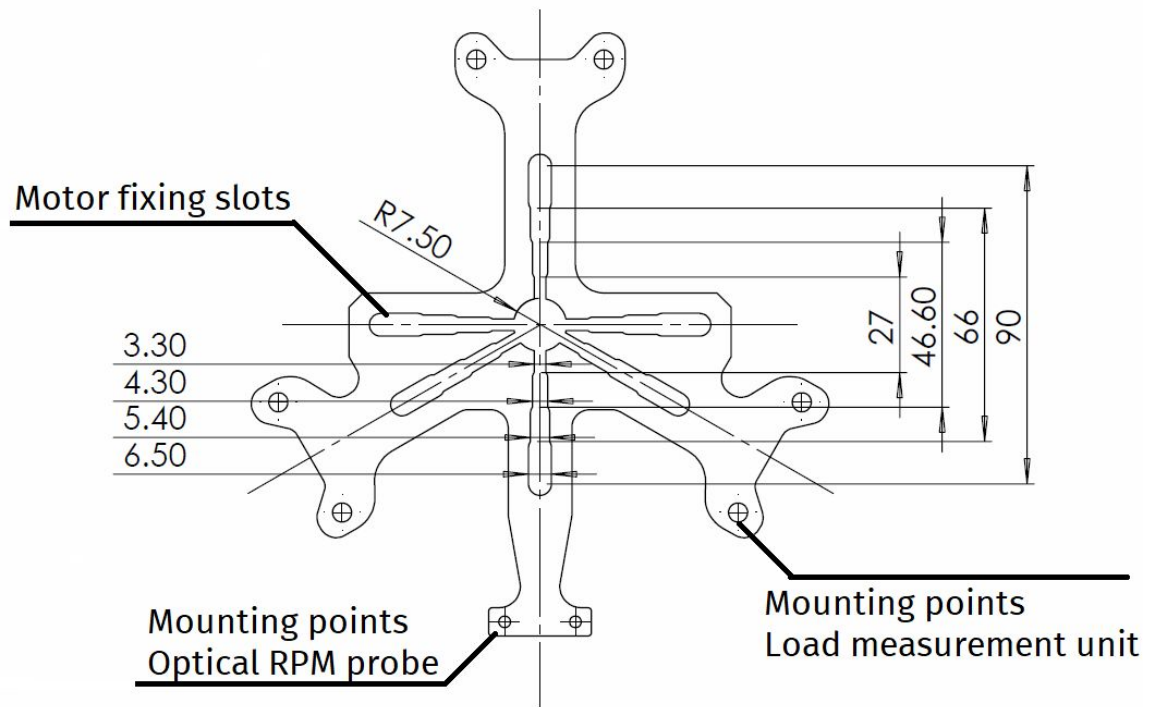

Fig. 4: Motor mount features for 25 kgf and 40 kgf

For the 75 kgf version, the motor can also be mounted directly on the heavy-load motor mount with M5, M6, M8 and M10 screws. This motor mount is specially designed for the 75 kgf that can support higher thrust and torque generated by the motor. The screws go through slots. There are slots at 0, 90, 120, 180, 240, 270 degrees in order to adapt to multiple motor geometries. For inrunner motor testing, there is also a center hole of $\phi 30$ that allows a rotating shaft through the plate.

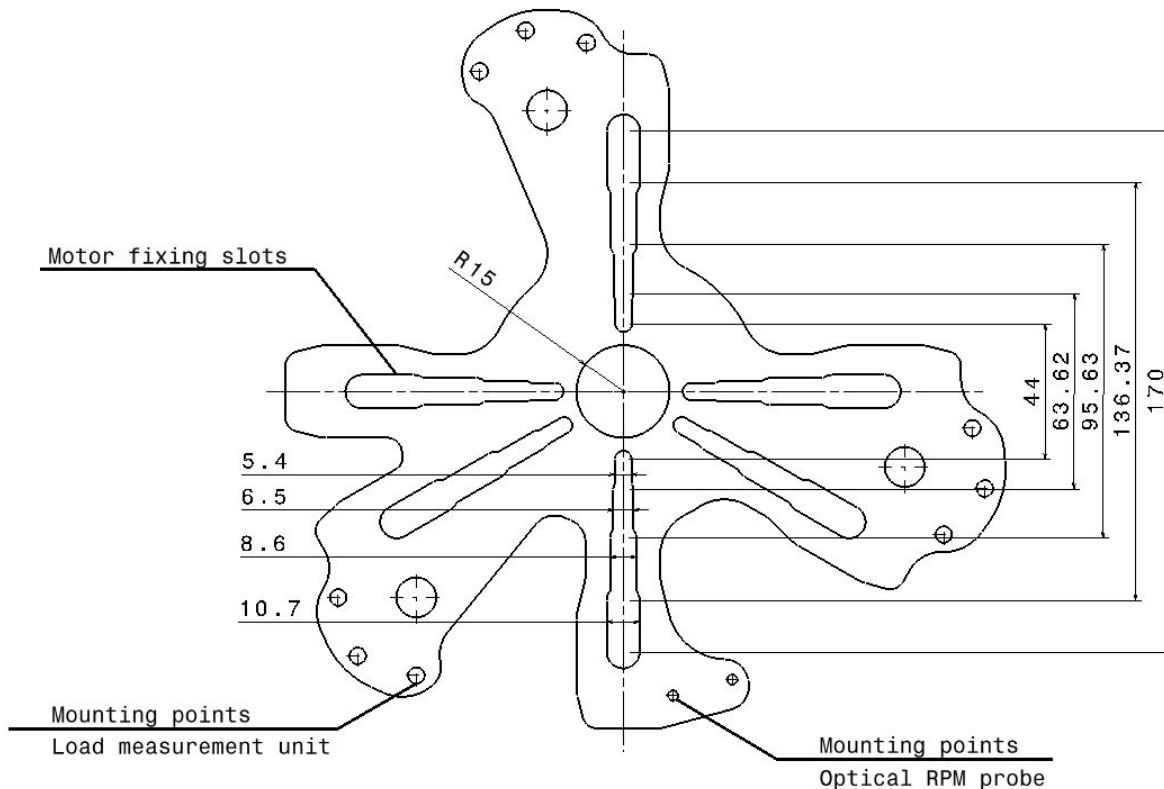

Fig. 5: Motor mount features for the 75 kgf version

If necessary, the customers who purchased the Series 1780 Dynamometer 75 kgf - 500 A can still use the thinner and smaller motor mount from the 25 kgf and 40 kgf.

If you are planning to test motors out of the specification of this motor mount, we offer a service to build a specialized motor mount at a reasonable fee. Please contact us with the dimensions and motor specifications. You can also machine your own mounting plate.

Safety

Read the manual for complete safety information.

Fast spinning propellers and motors can cause harm or even death of the user. Safety goggles must always be worn when testing. The software has automatic cutoffs based on the specifications of the device. These cutoffs can be further limited by the user to, for example, prevent a propeller from spinning too fast or a motor from using too much current.

The Series 1780 should be placed in a separated room. During the tests, no operator must be allowed to enter this room. Additionally, it is important to reinforce the walls, or have a safety cage alongside the propellers' spinning surface. These reinforced structures will protect the operator in case that any moving components breaks during operation.

It is highly recommended to use the proper fasteners provided in the package. As the Series 1780 supports measurements up to 75kgf of thrust for a single motor version or up to a total of 80kgf of thrust in a coaxial setup, it is mandatory to follow the instructions to install and to tighten those fasteners according to the user manual.

Always check that the fasteners are fully tightened before running any tests. Also check the room to remove metal chips or small loose parts on the floor before the test. Operations related to the electrical system must be accomplished by qualified personnel only. Cut the power before connecting or disconnecting the components.

Please read the product's safety instructions to obtain complete information.

Software

The software allows the user to control one or two motors simultaneously. It displays the sensor information in text and graphical form. The user can record all of the measured data with a single click, or record continuously. The output is a CSV file, which can be easily opened with a spreadsheet software or many other software packages.

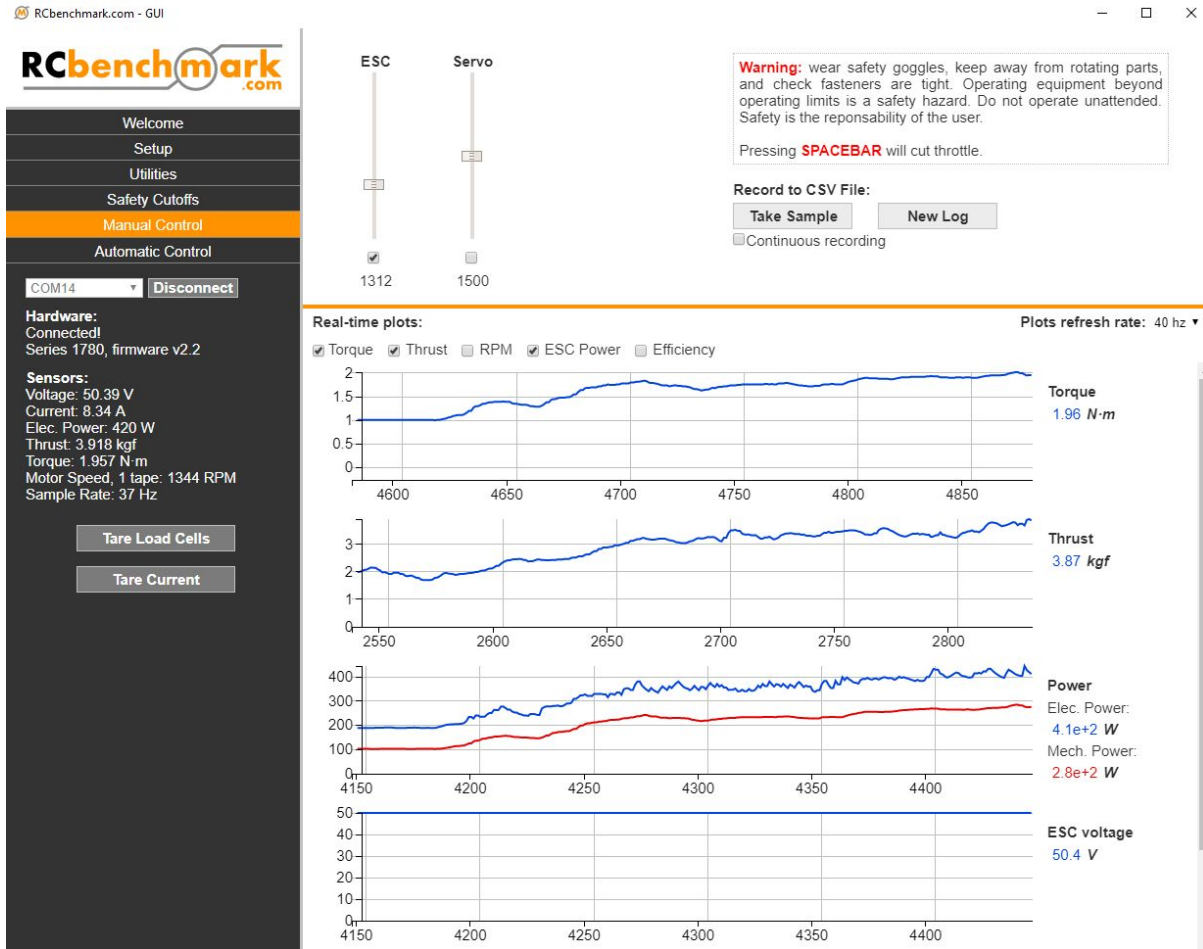

Deployment and custom use

The software is open source. It is an app that runs on Windows, Linux, and Mac. The firmware is written in C and the GUI is written in Javascript, which should be very simple to learn for users with C/C++ experience.